

# PT3.2-12

12Volt 3.2Ah

## Specifications

**Nominal Voltage(V)** 12V

### Nominal Capacity

20 hour rate	(0.25A to 10.50V)	3.2Ah
10 hour rate	(0.475A to 10.50V)	2.936Ah
5 hour rate	(0.85A to 10.20V)	2.712Ah
1 C	(5A to 9.60V)	1.01Ah
3 C	(15A to 9.60V)	1.14Ah

**Weight** Approx. 1.27kg(2.80Lbs.)

**Internal Resistance (at 1KHz)** Approx. 45mΩ

### Maximum Discharge Current for

**5 seconds:** 32A

### Charging Methods at 25°C (77°F)

#### Cycle use:

Charging Voltage 14.4 to 15.0V

Coefficient -5.0mV/°C/cell

Maximum Charging Current : 0.96A

#### Standby use:

Float Charging Voltage 13.5 to 13.8V

Coefficient -3.0mV/°C/cell

### Operating Temperature Range

Charge -15°C (5°F) to 40°C (104°F)

Discharge -15°C (5°F) to 50°C (122°F)

Storage -15°C (5°F) to 40°C (104°F)

### Charge Retention (shelf life) at 20°C (68°F)

1 month 92%

3 month 90%

6 month 80%

**Case Material** ABS UL94 HB

Option: Flammability resistance of (UL94 V-0)

**Terminal** F1 or F2 (Faston Tab 187 or 250)



## Dimensions

mm(inch)

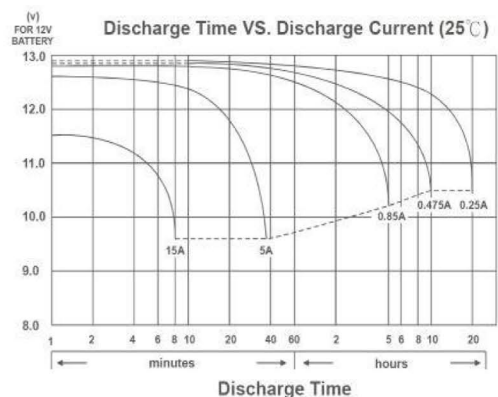
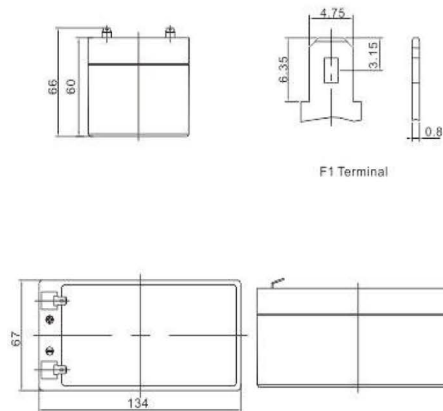

**Effect of Temperature on Capacity 25°C (77°F)**

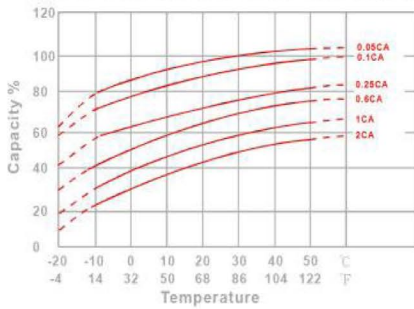

**Capacity Retention Characteristic**

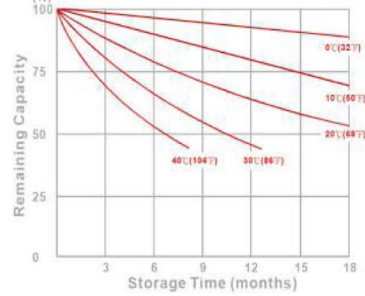

**Trickle (or float) Service Life**

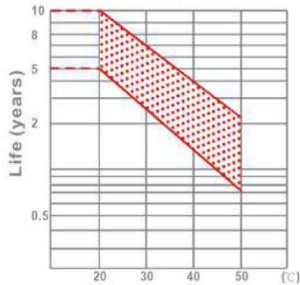

**Cycle Service Life**

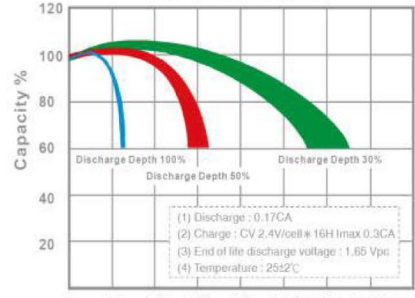

**Constant Current Discharge Characteristics : A (25°C)**

F.V/Time	5MIN	10MIN	15MIN	30MIN	1HR	2HR	3HR	4HR	5HR	8HR	10HR	20HR
1.60V	12.69	8.274	6.104	3.533	2.041	1.204	0.875	0.697	0.589	0.393	0.320	0.167
1.65V	12.23	8.028	5.944	3.455	2.003	1.187	0.864	0.688	0.582	0.389	0.317	0.165
1.70V	11.63	7.704	5.734	3.352	1.953	1.163	0.848	0.677	0.573	0.384	0.313	0.164
1.75V	10.87	7.286	5.460	3.218	1.887	1.132	0.828	0.662	0.561	0.377	0.308	0.161
1.80V	9.901	6.751	5.108	3.044	1.801	1.091	0.801	0.641	0.545	0.368	0.301	0.158
1.85V	8.713	6.082	4.663	2.822	1.691	1.038	0.765	0.615	0.524	0.355	0.291	0.154

**Constant Power Discharge Characteristics : WPC (25°C)**

F.V/Time	5MIN	10MIN	15MIN	30MIN	1HR	2HR	3HR	4HR	5HR	8HR	10HR	20HR
1.60V	21.84	14.28	10.83	6.51	3.87	2.32	1.70	1.36	1.15	0.78	0.64	0.33
1.65V	21.61	14.22	10.77	6.46	3.84	2.30	1.68	1.35	1.14	0.77	0.63	0.33
1.70V	20.78	13.80	10.48	6.31	3.76	2.26	1.66	1.33	1.13	0.76	0.63	0.33
1.75V	19.76	13.28	10.12	6.12	3.65	2.21	1.63	1.30	1.11	0.75	0.62	0.32
1.80V	18.32	12.52	9.61	5.85	3.50	2.14	1.58	1.27	1.08	0.74	0.60	0.32
1.85V	16.41	11.48	8.89	5.47	3.31	2.05	1.52	1.22	1.04	0.71	0.58	0.31

(Note) The above characteristics data are average values obtained within three charge/discharge cycle not the minimum values.